

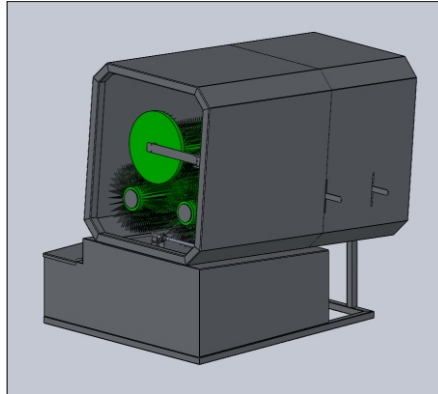

GemiClean DW model.

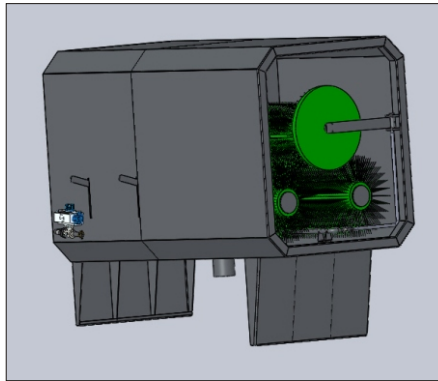

Incl. water saving system.



Excl. water saving system.

GemiClean DW-Model *Drum Washing Machine.*

Typical features:

- ✎ Suitable for open top drums up to 220 ltr.
Min. Ø 300 mm.
Max. Ø 700 mm. Max. Height 950 mm.
- ✎ Reliable and proven design.
- ✎ Full stainless steel execution.
- ✎ Robust and easy to operate.
- ✎ Machine dimensions: 1.000 x 2.000 x 1.200 mm (W x D x H)
- ✎ Cleaning of inside & outside by means of 3 rotating brushes driven by one electro motor. Brushes run at different speeds causing drum to rotate.
- ✎ Automatic reverse movement of brush motor based on time setting.
- ✎ Control panel with adjustable timer.
- ✎ Separate non-rotating brush for cleaning of the bottom
- ✎ Standard suitable for cleaning with water.
- ✎ Water consumption during 2-minute cleaning cycle: approx. 30 ltr. per drum without water saver. With water saver approx. 6 ltr. Water saver is optional.
- ✎ Capacity: approx. 30 drums per hour.
- ✎ Optional in ATEX execution when cleaning with solvent. Eex proof Zone II (3G) or Zone I (2G).
- ✎ Optional with soap dispenser for enhanced cleaning effectiveness.